

WORKING DIMENSIONS

Length:	11.5 m (37 ft. 9 in.)
Width:	8 m (26 ft. 3 in.)
Height:	5.6 m (18 ft. 4 in.) Arm excluded
Weight:	45 ton

INTERNATIONAL SHIPPING DIMENSIONS

Shipping Method:	Five (5) containers 40'
------------------	-------------------------

FLOTATION

Dimensions:	Two (2) pontoons 11.5 m x 1.8 m x 1.25 m With Central Floater
Draft:	80 – 90 cm

WORKING CAPACITY

Capacity:	450 m ³ /h – 800 m ³ /h (1981 gpm – 3520 gpm)
Head:	56 m – 22 m (183 ft. – 72 ft.)
Working Depth:	Up to 6.5 m (21 ft. 4 in.)
Arm Swing:	± 15°

ENGINE

Type:	CAT or IVECO Diesel engine (260kW/350HP) (Other brands on demand)
Fuel Capacity:	10.000 liters
Fuel Consumption:	250 gr/kW/h

Power Packs can also be based on Electric motors

SUBMERSIBLE DREDGE PUMP

Type:	HY85/160A/B/HC
Discharge Diameter:	200 mm – 250 mm (8in. – 10 in.)
Impeller Diameter:	440 mm (1 ft. 5 in.) / 3 blades, closed
Max. Solid Handling:	60 mm (2.36 in.) / 90 mm (3.54 in.)
Speed:	980 r.p.m. / 1450 r.p.m (variable)
Oil requirements:	240 l/min @ 300 bar
Power:	120 kW (165HP)

OPTION 1 – EXCAVATORS

Diameter:	700 mm (2 ft. 3 in.)
Replaceable Teeth:	Regular, sharp or wide head teeth
Drive:	Radial piston hydraulic motor
Oil requirements:	22 l/min - 29 l/min - 36 l/min @ 300 bar
Weight:	500 kg each
Speed:	30 r.p.m – 40 r.p.m – 50 r.p.m
Torque:	311 kgm – 313 kgm – 314 kgm
Rotation:	Both directions

OPTION 2 - JET RING SYSTEM

Water capacity:	20 m ³ /h – 200 m ³ /h
Pressure:	6 bar – 7 bar
Drive:	Horizontal high pressure pump

PROPULSION

Primary System:	Four (4) 50 m steel Winches (available up to 211 m)
Secondary System:	Helix Propeller (OPTIONAL)

ELECTRICAL SYSTEM

Voltage:	On request
Alternator Output:	24 V

SAFETY FEATURES

Includes:	2 fire extinguishers, folding cabin door, warning horn, life rings, life jackets, locking power unit.
-----------	---

ANTI-CORROSION FEATURES

Includes:	Hull below deck painted with marine-grade epoxy. Hull above deck painted with polyurethane epoxy and remaining components coated with heavy-duty powder coating all suitable for salt-water service.
-----------	--

EQUIPMENT	BASIC	STANDARD	FULL OPTIONAL	HIGH DEPTH*
Winches for moving	X	X	X	X
Night time operating lights	X	X	X	X
Hydraulic Arm	X	X	X	X
Operator Cabin	X	X	X	X
Control Panel	X	X	X	X
Grapple Tool		X	X	X
A/C and Heating		X	X	X
Digital Depth Gauge		X	X	X
Dredge GPS System			X	X
Helix Propeller			X	X
Sound Proof Canopy			X	X
Umbilical Hose				X
Hydraulic Spooler (up to 300m)				X
Pressure Compensator				X
TIER3 B (OPTIONAL)				

ANTI-CORROSION PACKAGE AVAILABLE ON REQUEST (PH 2 – 12)

*High Depth Version incurs in different hull dimensions



THE DREDGE

Hydraulic Power Pack

- Separate oil pumps for pump and excavators
- Sound Proof Canopy
- IVECO, VOLVO or CAT Diesel engine
- Closed hydraulic circuit

Operator Cabin

- Complete Control panel
- Equipped with heating and air conditioning
- Operator chair
- Safety equipment
- Equipment status
- Emergency Stop controls



Hydraulic Arm

- Carefully move pump up and down
- Depth measuring pulley
- Reach up to 6.5 m
- Possibility to use other hydraulic tools

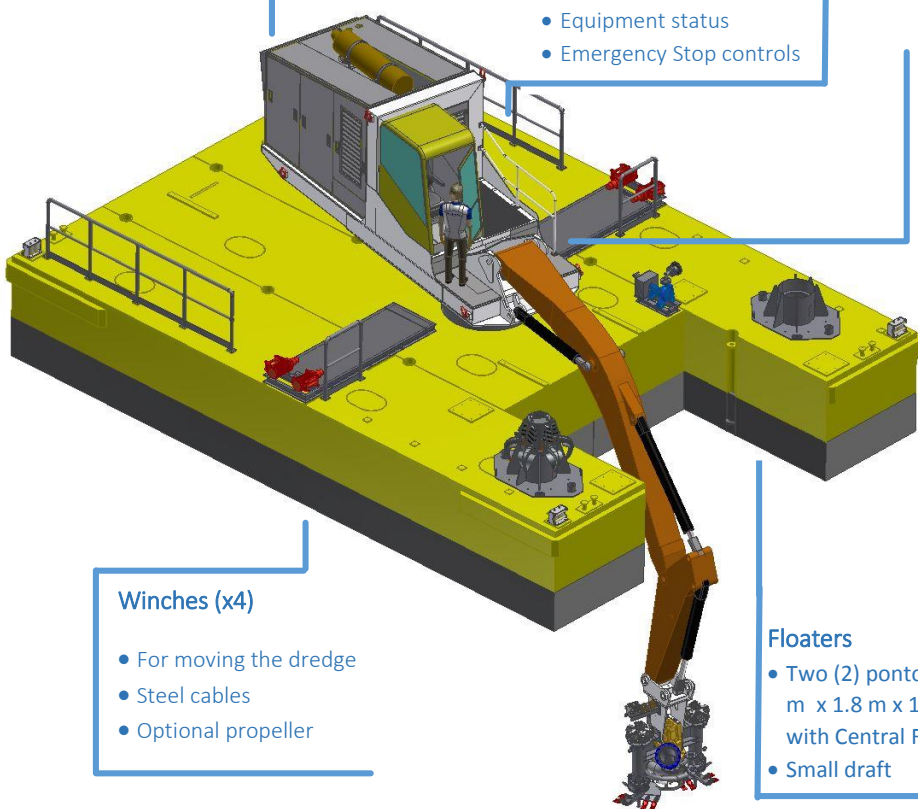

Winches (x4)

- For moving the dredge
- Steel cables
- Optional propeller



Floaters

- Two (2) pontoons 11.5 m x 1.8 m x 1.25 m with Central Floater
- Small draft

THE PUMP

Excavators

- Diameter: 700mm
- Replaceable teeth
- Radial piston hydraulic motor
- Oil requirement: 35 l/min each
- Weight: 500kg
- Speed: 30 r.p.m. – 50 r.p.m.
- Torque: 314 kgm
- Rotates in both directions

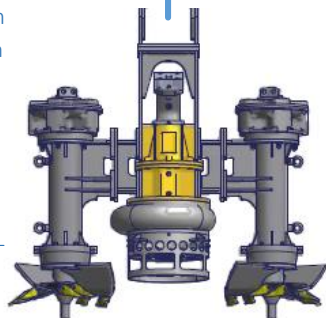

Pump

- Capacity: 450 m³/h – 800 m³/h
- Head: 56m – 22m
- Discharge diameter: 200mm – 250mm
- Suction diameter: 548mm
- Impeller diameter: 440mm
- Max. solid handling: 60mm/90mm
- Speed: 1480 r.p.m.
- Oil requirement: 240 l/min

Jet-Ring System

- Water Capacity: 20 m³/h – 200 m³/h
- Pressure: 6 bar – 7 bar
- Drive: Horizontal high pressure pump

