

# Hydraulic pump

## HY300

### PUMP SPECIFICATIONS

Max Capacity [m <sup>3</sup> /h]	1200
Max Head [m]	44
Impeller diameter [mm]/type	760 /2 blades closed
Flanged bore size [DN/PN]	DN250/PN10
Solid handling [mm]	120
Weight [kg]	3500

### HYDRAULIC MOTOR

Motor displacement [cc]	500
Max. oil flow rate[l/min]	380
Max. pressure [bar]	350
Power [kW-HP]	220 - 290
Speed [RPM]	750

### MATERIALS

Casing	Spheroidal cast iron EN-GJS500-7 (EN1563)
Motor housing	Cast iron EN-GJL-250 (EN 1561)
Wear parts	High chrome EN-GJN-HV600 (XCr18) (EN12513)
Main shaft	High tensile steel 39NiCroMo3 (AISI 9840)

### SEALS / LUBRICANT

Motor side seals	3 lip seals (2 BUNA + 1 PTFE)
Impeller side seals	5 lip seals (3 BUNA + 2PTFE) + 1 V-ring (TPU)
Oil type	ISO 32

### DIMENSIONS [mm]

H	W	D	F	H1	A	B	C
2400	1600	1357	1015	470	652	750	576

### PERFORMANCE CURVES

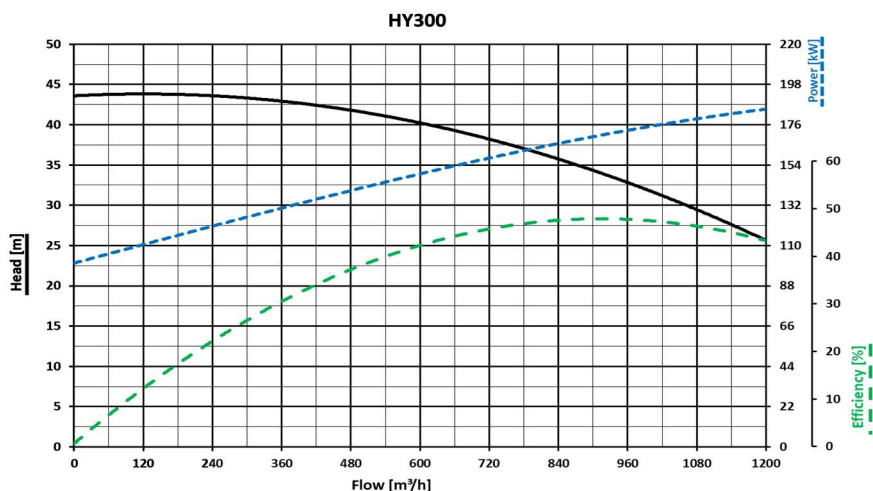

We reserve the right to make changes without notice

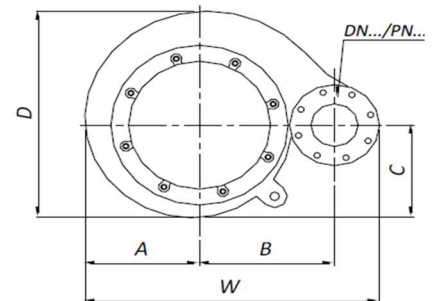
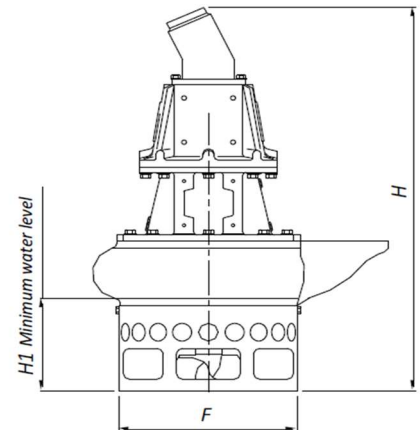
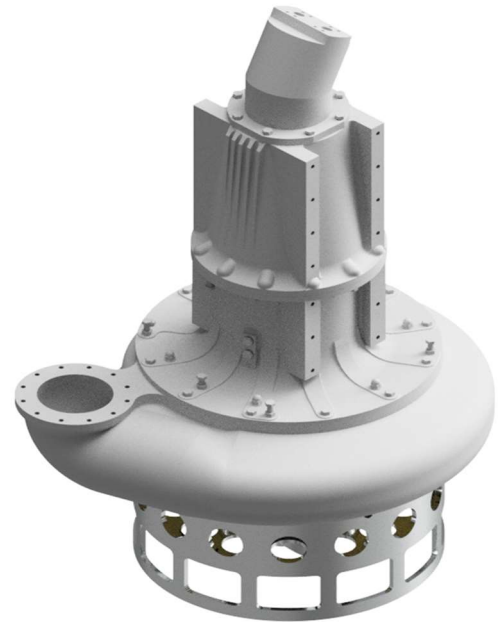

# HY300

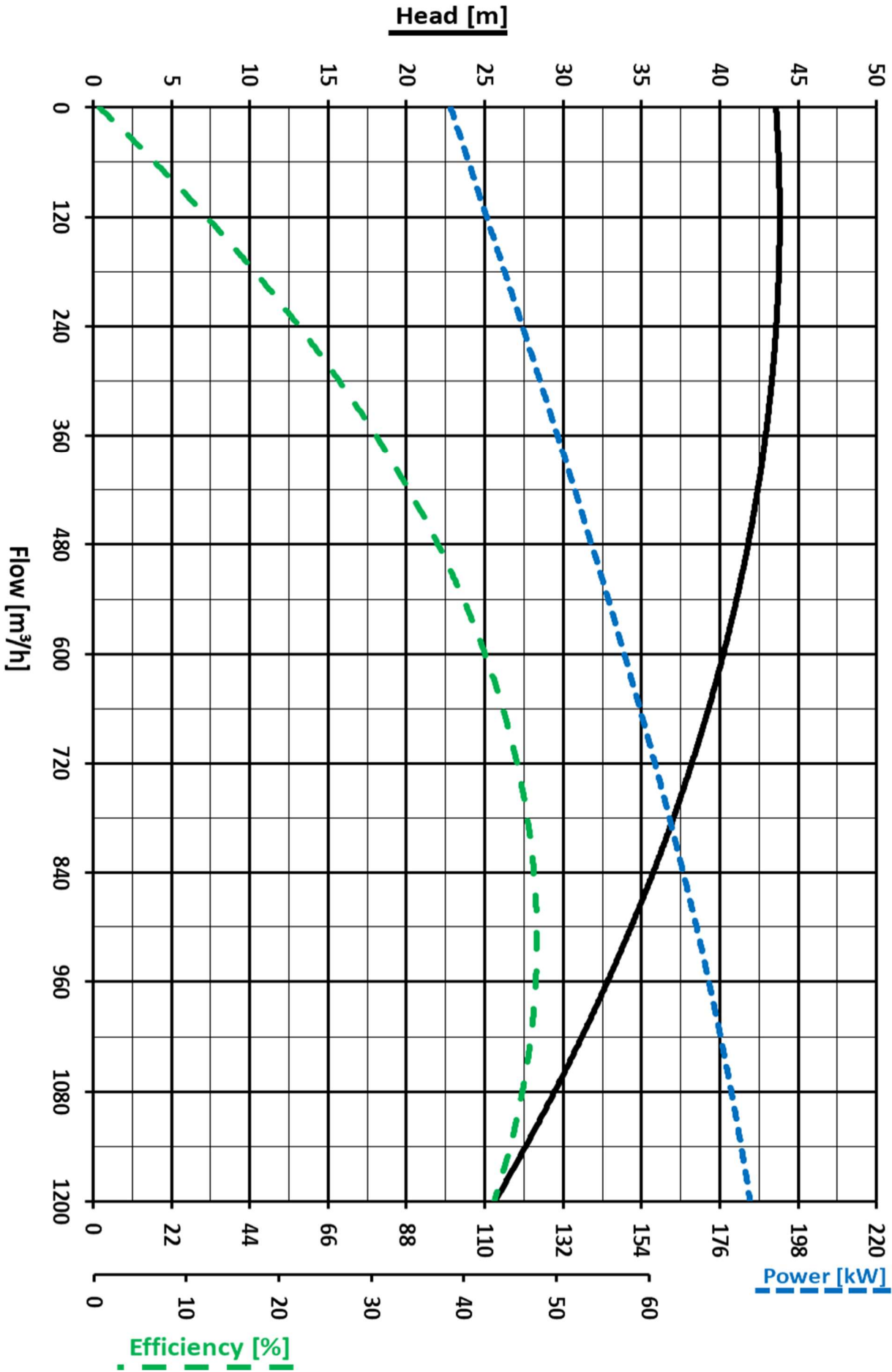

We reserve the right to make changes without notice