

# Hydraulic excavator

## EXHY20 (/S /H)

### EXCAVATOR SPECIFICATIONS

Torque (kNm)	2.6
Blades/Teeth n°	3/6
Weight [kg]	500

### HYDRAULIC MOTOR

Motor displacement [cc]	700
Max. oil flow rate [l/min]	35
Max. pressure [bar]	250
Power [kW-HP]	14.5-19.8
Speed [RPM]	50

### LUBRICANT

Oil type	ISO 320
----------	---------

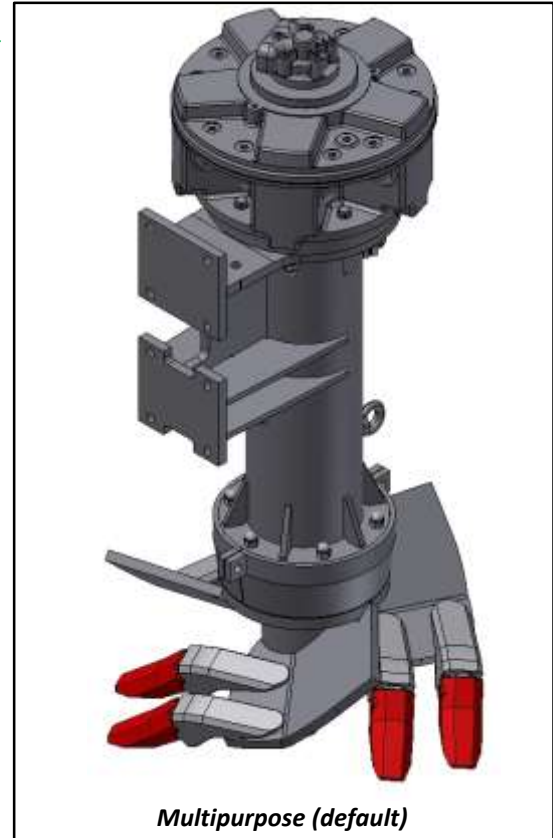
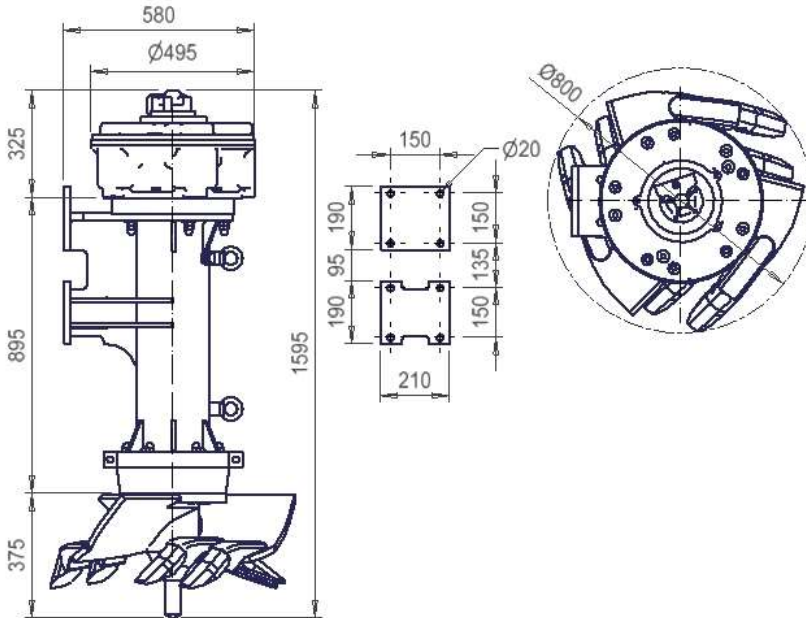

Multipurpose (default)

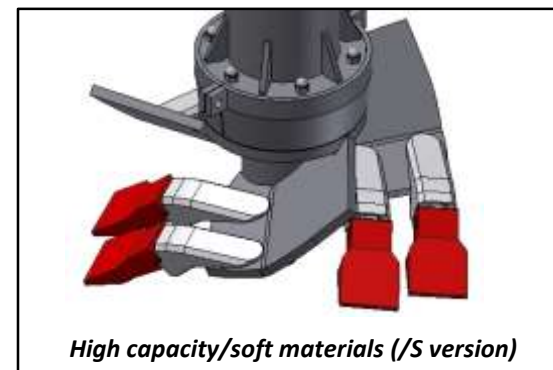

High capacity/soft materials (/S version)

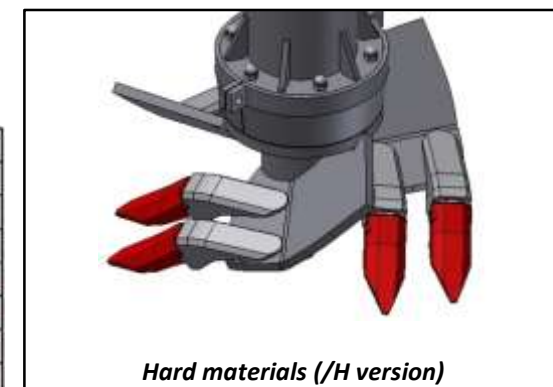

Hard materials (/H version)

