

Hydraulic pump

HY600

PUMP SPECIFICATIONS

Max Capacity [m ³ /h]	1800
Max Head [m]	70
Impeller diameter [mm]/type	760 /2 blades closed
Flanged bore size [DN/PN]	DN300/PN10
Solid handling [mm]	120
Weight [kg]	3550

HYDRAULIC MOTOR

Motor displacement [cc]	1000
Max. oil flow rate[l/min]	950
Max. pressure [bar]	300
Power [kW-HP]	475 - 630
Speed [RPM]	950

MATERIALS

Casing	Spheroidal cast iron EN-GJS500-7 (EN1563)
Motor housing	Cast iron EN-GJL-250 (EN 1561)
Wear parts	High chrome EN-GJN-HV600 (XCr18) (EN12513)
Main shaft	High tensile steel 39NiCroMo3 (AISI 9840)

SEALS / LUBRICANT

Motor side seals	3 lip seals (2 BUNA + 1 PTFE)
Impeller side seals	5 lip seals (3 BUNA + 2PTFE) + 1 V-ring (TPU)
Oil type	ISO 32

DIMENSIONS [mm]

H	W	D	F	H1	A	B	C
2400	1600	1357	1015	470	652	750	576

PERFORMANCE CURVES

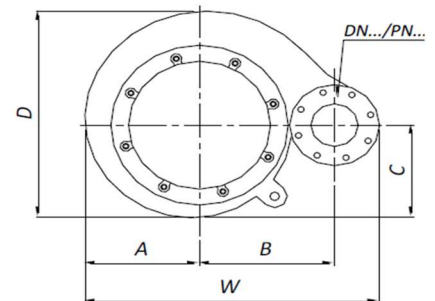
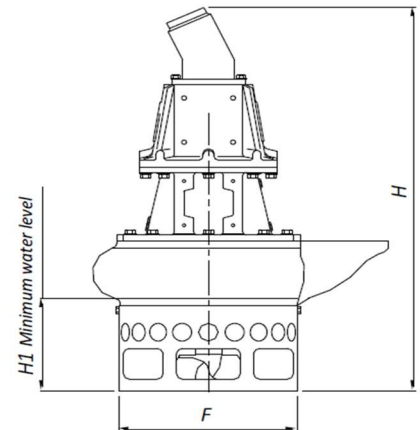
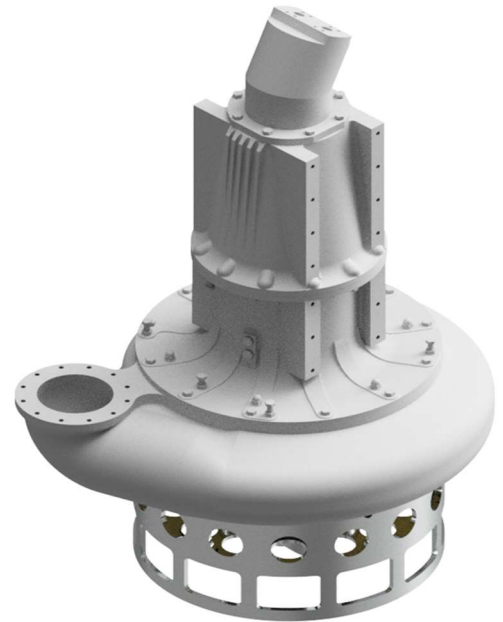
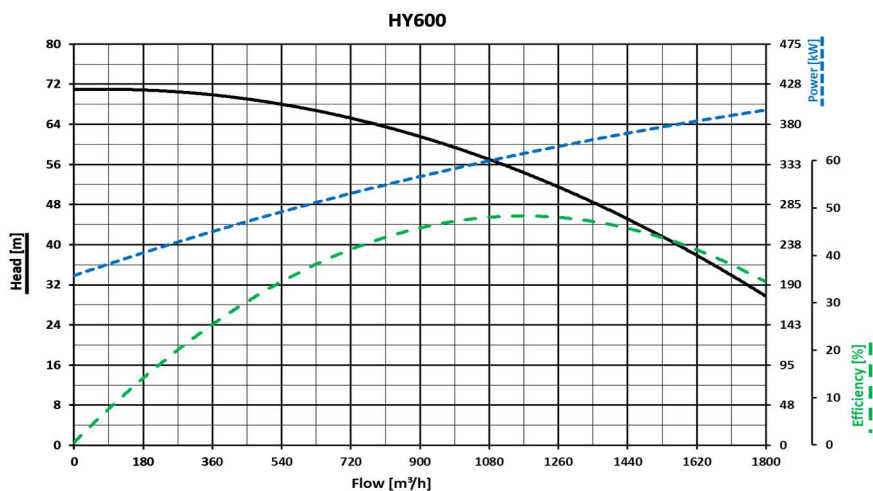

HY600

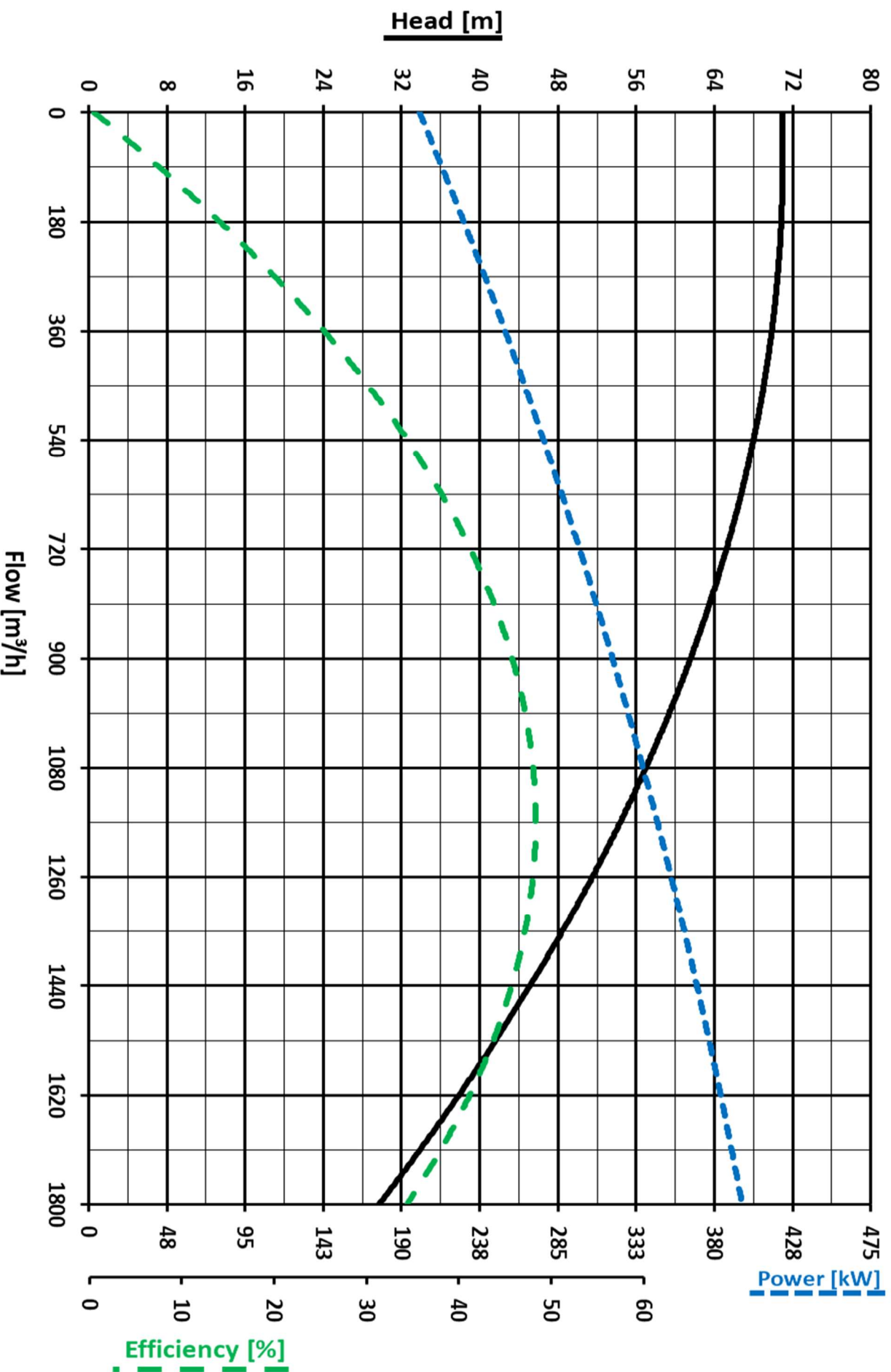

We reserve the right to make changes without notice