

# Cutter Head

## DTM85

### TECHNICAL SPECIFICATIONS

Torque [kNm]	4.9
Blades/Teeth n°	6/18
Weight [kg]	450

### HYDRAULIC MOTOR

Displacement [cc]	1240
Max. oil flow rate [l/min]	40
Max. pressure [bar]	250
Power [kW-HP]	16.7-22.6
Speed [RPM]	30

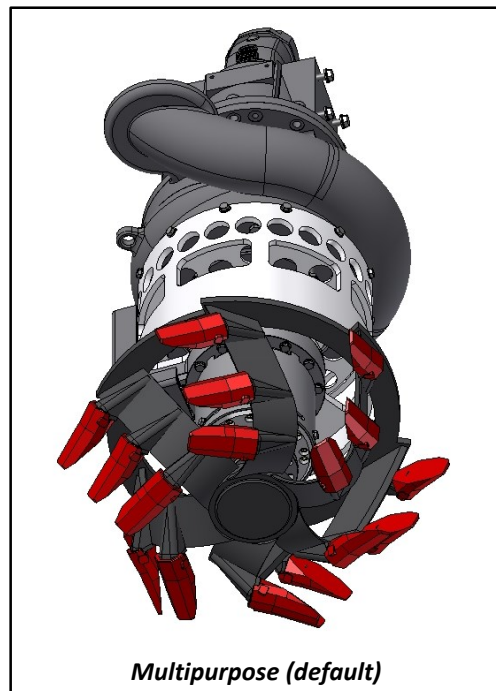
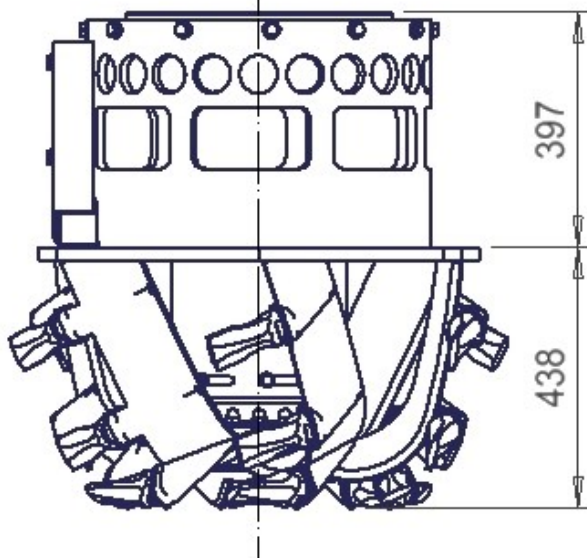
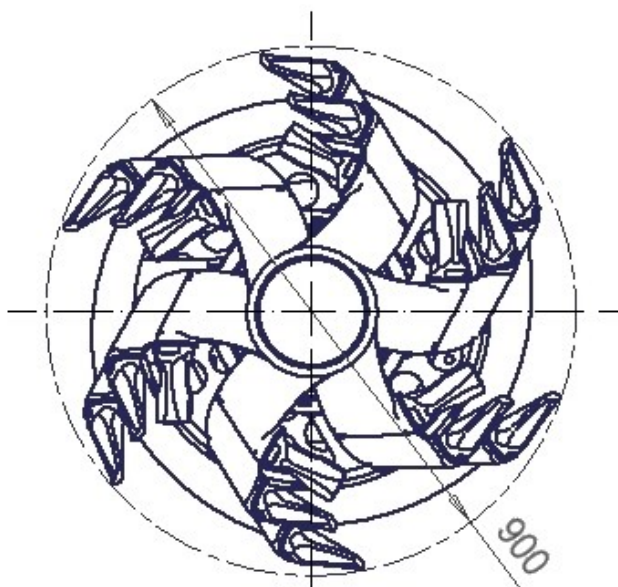

*Multipurpose (default)*

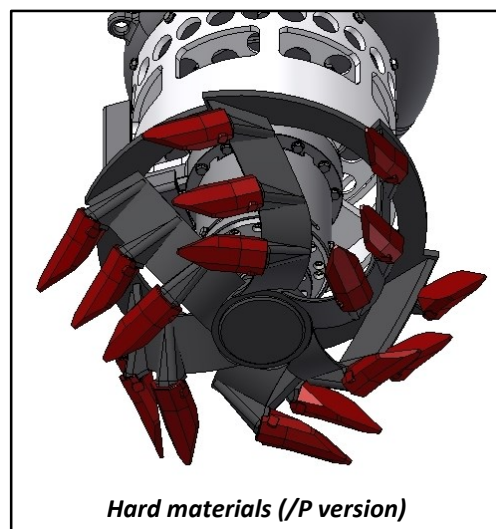

*Hard materials (/P version)*