

WORKING DIMENSIONS

Length:	11.5 m (37 ft. 8 in.)
Width:	8 m (26 ft. 3 in.)
Height:	6.5 m (21 ft. 4 in.)
Weight:	40 tons

INTERNATIONAL SHIPPING DIMENSIONS

Shipping Method:	Four (4) containers 40'
------------------	-------------------------

FLOTATION

Dimensions:	Two (2) pontoons 11.5 m x 1.8 m x 1.8 Catamaran Style
Draft:	1 – 1.2 m

WORKING CAPACITY

Capacity:	1000 m ³ /h – 1400 m ³ /h (4400 gpm – 6164 gpm)
Head:	52 m – 32 m (134 ft. – 144 ft.)
Working Depth:	Up to 100 m (328 ft.)

ENGINE

Type:	CAT or IVECO Diesel engine (470kW/630HP) (Other brands on demand)
Fuel Capacity:	10.000 liters
Fuel Consumption:	250 gr/kW/h
Power Packs can also be based on Electric motors	

SUBMERSIBLE DREDGE PUMP

Type:	HY400A/B
Discharge Diameter:	300 mm – 350 mm (12 in. – 14 in.)
Impeller Diameter:	760 mm (2 ft. 6 in.) / 2 blades, closed
Max. Solid Handling:	120 mm (4.72 in.)
Speed:	750 r.p.m. - 850 r.p.m. (variable)
Oil requirements:	605 l/min @ 300 bar
Power:	300 kW (405HP)

OPTION 1 - EXCAVATORS

Diameter:	1000 mm (3 ft. 3 in.)
Replaceable Teeth:	Regular, sharp or wide head teeth
Drive:	Radial piston hydraulic motor
Oil requirements:	35 l/min - 46 l/min - 58 l/min @ 350 bar
Weight:	550 kg each
Speed:	30 r.p.m – 40 r.p.m – 50 r.p.m
Torque:	501 kgm – 504 kgm – 507 kgm
Rotation:	Both directions

OPTION 2 - JET RING SYSTEM

Water capacity:	20 m ³ /h – 200 m ³ /h
Pressure:	6 bar – 7 bar
Drive:	Horizontal high pressure pump

PROPULSION

Primary System:	Four (4) 50 m steel Winches (available up to 211 m)
Secondary System:	Helix Propeller (OPTIONAL)

ELECTRICAL SYSTEM

Voltage:	On request
Alternator Output:	24 V

SAFETY FEATURES

Includes:	2 fire extinguishers, hand rail, folding cabin door, warning horn, life rings, life jackets, locking power unit.
-----------	--

ANTI-CORROSION FEATURES

Includes:	Hull below deck painted with marine-grade epoxy. Hull above deck painted with polyurethane epoxy and remaining components coated with heavy-duty powder coating all suitable for salt-water service.
-----------	--

EQUIPMENT	BASIC	STANDARD	FULL OPTIONAL	HIGH DEPTH
Winches for moving	X	X	X	X
Night time operating lights	X	X	X	X
Hydraulic Hoist	X	X	X	X
Operator Cabin	X	X	X	X
Control Panel	X	X	X	X
A/C and Heating		X	X	X
Digital Depth Gauge		X	X	X
Dredge GPS System			X	X
Helix Propeller			X	X
Umbilical Hose			X	X
Sound Proof Canopy			X	X
Spring driven Spooler (up to 15m)			X	
Hydraulic Spooler (up to 300m)				X
Pressure Compensator				X
TIER3 B (OPTIONAL)				

ANTI-CORROSION PACKAGE AVAILABLE ON REQUEST (PH 2 – 12)



THE DREDGE

Hydraulic Power Pack

- Separate oil pumps for pump and excavators
- Sound Proof Canopy
- IVECO or CAT engine
- Remote or Radio controlled
- Closed hydraulic circuit

Operator Cabin

- Complete Control panel
- Equipped with heating and air conditioning
- Operator chair
- Safety equipment
- Equipment status
- Emergency Stop controls



Hydraulic Hoist

- Carefully move pump up and down
- Depth measuring pulley
- Supply Oil hoses

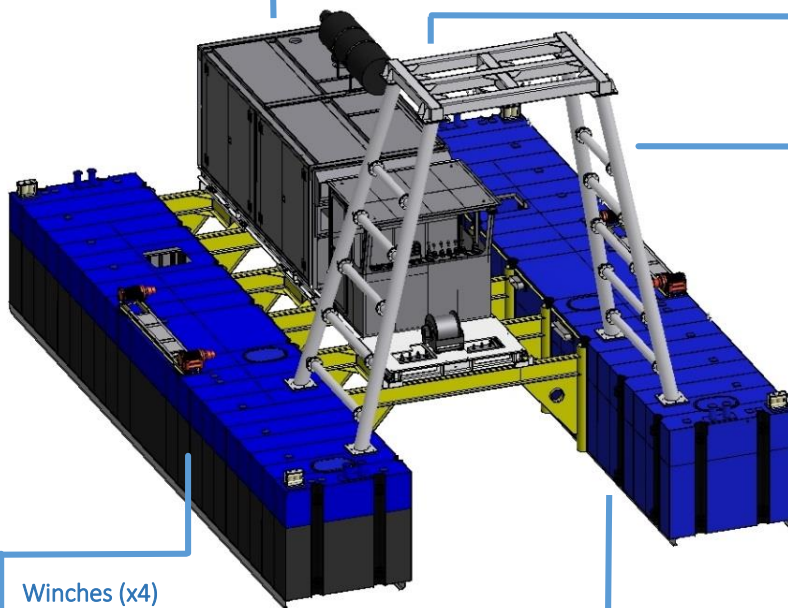

Winches (x4)

- For moving the dredge
- Steel cables
- Optional propeller

Floater

- Catamaran style
- Two (2) pontoons 11.5 m x 1.8 m x 1.8 m
- Small draft



THE PUMP

Excavators

- Diameter: 1000mm
- Replaceable teeth
- Radial piston hydraulic motor
- Oil requirement: 58 l/min each
- Weight: 550kg
- Speed: 30 r.p.m. – 50 r.p.m.
- Torque: 507 kgm
- Rotates in both directions

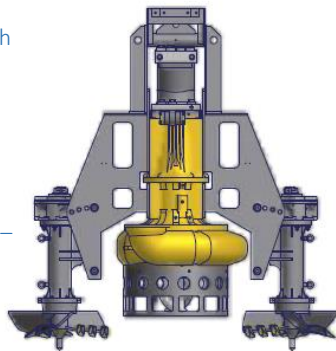

Pump

- Capacity: 1100 m³/h – 1300 m³/h
- Head: 52m – 32m
- Discharge diameter: 300mm – 350mm
- Impeller diameter: 760mm
- Max. solid handling: 120mm
- Speed: 850 r.p.m.
- Oil requirement: 605 l/min

Jet-Ring System

- Water Capacity: 20 m³/h – 200 m³/h
- Pressure: 6 bar – 7 bar
- Drive: Horizontal high pressure pump

